

Glorystar: Professional Install Guide



Guide Contents:

- Dish Assembly
- Activating Receiver
- Locating the Satellite
- Multi Room Diagrams

IMPORTANT: *There are several differences between the installation of a FSS satellite package and a DSS (Dish Network) or DBS (DirecTV) system. Please, READ the following information prior to arriving at customer's site to save time and reduce costly errors.*

1. FSS Installations take longer

Professional Installers with previous FSS Experience
(typical time is 2 hours)

Professional Installers with no FSS Experience
(typical time is 3-4 hours)

2. FSS systems use linear LNBFs

Linear LNBF must be rotated/skewed based on installation site location.
Get customized rotation/skew information for any installation location
<http://www.geosatfinder.com>

3. FSS signals are weaker

(GEOSATpro receivers include signal strength meter)
FSS systems require a larger and more precisely tuned dish. Consult your signal meter instruction manual for linear LNBF settings.

4. Larger dishes require Mast Support Tripod Legs

(Mast Support Tripod Legs are included with GEOSATpro dishes)
Larger dishes need additional support against wind. The mast will fail without the installation of the Tripod Legs.

Please call **888-597-0728** for troubleshooting assistance.

7am - 4pm M - F



If this install cannot be completed for issues related to LOS or faulty equipment, installers must contact Glorystar at **888-597-0728** from the job site to arrange for a RMA.

Satellite Meters

A digital identification meter such as a SatHawk, BirDog or Super SatBuddy will simplify the installation process. Please consult with the meter owners manual for correct meter operation procedures.

Install Procedure with a Signal Identification Meter

Connect LNBF and use a data set for standard LNB type LO 10750, KU, Galaxy 19 97W, Horizontal and Vertical transponders. Peak and Balance for maximum Signal Quality (**Q**) for G 19. Verify the Signal Quality averaged above 50% on the Glorystar receiver channels 901 - TP Freq. 12152, 106 - TP Freq. 11842 and 113 - TP Freq. 12115. Perform an OTA update following directions on Page 49 of this guide to update the channel list.

Note: Birdog meters may have difficulty detecting weaker FSS type signals and must have the BER setting changed in the main set-up menu. Change the BER setting to LOG (logarithmic) and the meter will become much more sensitive to the weaker FSS type satellites.

Professional Installer Tip:

If you are having trouble locating the satellite, remove the Glorystar standard linear polarity LNBF from the clamp and install a DirecTV circular polarity LNBF. Locate the DirecTV 101w satellite with your meter or a DirecTV receiver. Mark the mast and mast clamp with the 101W satellite position. Replace the Glorystar linear polarity LNBF into the clamp and set the skew. Rotate the dish approximately 6 degrees to the East (1/4" on the mast marking). The dish is now roughly aimed and will only require fine AZ/EL tuning for optimal reception of the Galaxy 19 satellite @ orbital slot 97W.

Dish and LNBF Assembly

Dish Reflector Accuracy

Before assembling the dish it is **Extremely Important** to verify that the reflector was not warped during shipping. Failure to check for dish warping could lead to many frustrating hours of trying to locate the satellite. This simple test may be the most important step in a successful installation!



Bad - Warped Reflector



Good - Reflector

Find a perfectly flat surface such as a garage cement floor and lay the reflector face down. Are the edges of the reflector laying perfectly flat? If any area of the edge is raised by even an 1/8th of an inch reception of the satellite signal will be affected!

If you cannot find a perfectly flat surface or if the dish is already installed, perform the string test.

Tape a string horizontally from edge to edge across the center of the dish. Tape a second string vertically from top to bottom on the edges of the dish.

If the strings do not lightly touch in the center, the dish is warped and it must be corrected before aiming the dish.

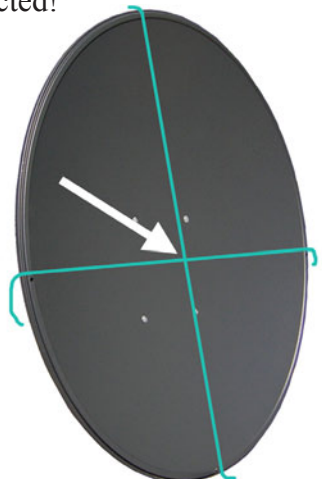

To correct a warped reflector, hold the dish like a steering wheel and quickly thrust the reflector away from your body like the motion of passing a basketball. This action will cause the reflector to slightly flex and spring back into the factory pressed shape.

Check for correction with the string test. It may be necessary to repeat the flexing process several times until the reflector edges are uniformly flat.



The Mast or mounting post must be **PERFECTLY** plumb. If the mast is not plumb, the skew angle will not be correct and the dish will be difficult to aim!

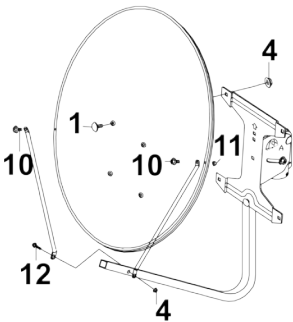

After verifying the Reflector is not warped, mount the Reflector to the Elevation Bracket and install the two LNBF Arm Side Supports. The Side Arm Supports will perfectly center and support the LNBFs for optimal reception.

The Tripod Legs must be used to support the post



Most installations in the US and Canada will use Elevation Scale “A” type assembly. The dish has been correctly assembled for Measuring the Dish Elevation Angle using Scale A (10 - 60 degrees) if an upside letter B is visible stamped on the Post Clamp on the left side of the Post Clamp.

The Elevation Pointer is visible through the scale next to the nut that secures the elevation.

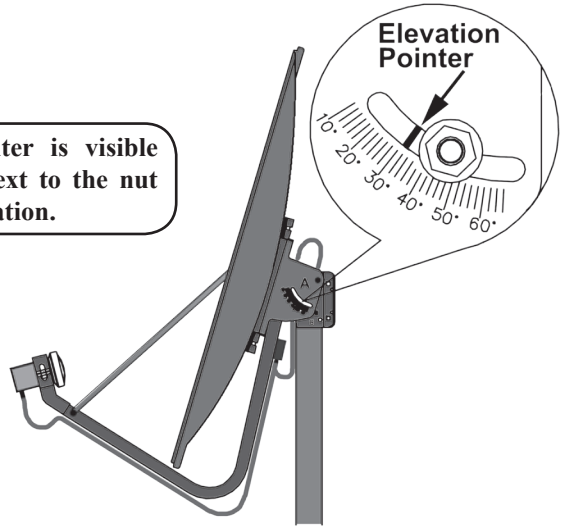

Set the LNBF Rotation (Skew Angle) to the setting specified in the aiming instructions provided with your system. The LNBF rotates in the circular clamp until the centering line on the top of the LNBF aligns with the LNBF Rotation angle. Each mark indicates 5 degrees.

When standing in front of the dish and looking at the back of the LNBF and towards the reflector, rotate the LNBF counter clockwise (left) for a positive (+) LNBF Rotation (Skew) setting and Clockwise (right) for a negative (-) LNBF Rotation (Skew) setting.

Counter (+) (-) Clockwise
Clockwise



Example: Positive +20 LNBF Rotation (skew) setting.



Connect Receiver to a TV

If you do not have a Signal Identification Satellite Meter for the install, the easiest way to aim the satellite dish is to temporarily place the satellite receiver connected to a small television at the dish antenna mounting location.

Activating the Glorystar Receiver

1. Highlight English Press **OK**
2. Highlight the System Type **GLORystAR**. Press **OK**
3. Select your local Time Zone
4. Select Daylight Savings ON/OFF (The time will now be automatically synchronized via the satellite each time the receiver is placed on Glorystar Channel 1 for a minimum of 10 seconds)
5. Highlight **NEXT**. Press **OK**
6. Connect the coaxial cable from the LNBF on the dish antenna to the SAT IN port on the back of the satellite receiver.
7. Press **OK** to display the Signal Strength and Signal Quality meter with Signal Quality Tone Beeper on the connected television.

The receiver will automatically tune to **Channel 901, RT News Channel TV**. A low beeping sound will be emitted from the TV speakers. Press the Blue Button on the remote to toggle ON/OFF the beeping sound.

Locate and Peak Satellite Signal

Aim the dish towards the Galaxy 19 satellite located in the 97W orbital position. Observe the Signal Quality (**Q**) reading on **Channel 901, RT News Channel** and very slowly pan the dish.

If the dish is panned beyond 15 degrees from the satellite compass reading and no Signal Quality (Q) is detected or television programming displayed, return the dish to the starting position then slowly sweep 15 degrees in the opposite direction.

When the correct satellite is found the beeping sound changes to a higher tone and the Signal Quality (Q) bar turns Green. The meter will display an increased Signal Quality (Q) reading. **RT News Channel** programming will be visible.

If no Green Signal Quality (Q) reading is detected, increase or decrease the elevation by one degree increments and repeat the slow sweep. The elevation may need to be adjusted +/- 5 degrees depending on the post being plumb. Move the dish very slowly to allow the receiver to process the signal information. A movement of just 1/16th of a inch can result in a perfect or no signal.

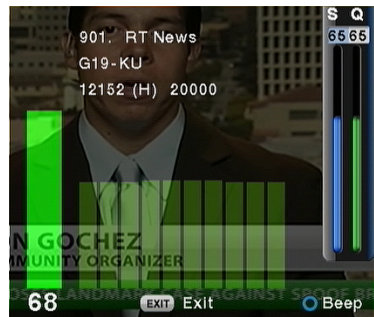
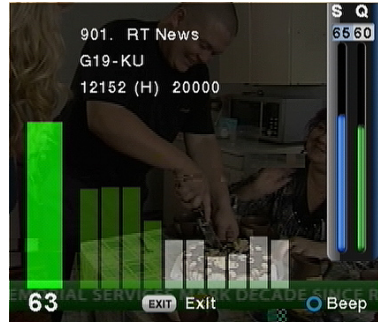

This process may need to be repeated many times to aim and peak the quality of the signal.

When the dish is correctly aimed, the **RT News Channel** television programming will be displayed and the Signal Quality (Q) reading will read 50% or higher. A stable signal on the Spectrum Graph with minimal ripple indicates that the signal is optimized.

The Signal Level (S) is not important in detecting the satellite. Signal Level readings indicate a connection to a functioning LNBF, not the detection of the correct satellite.

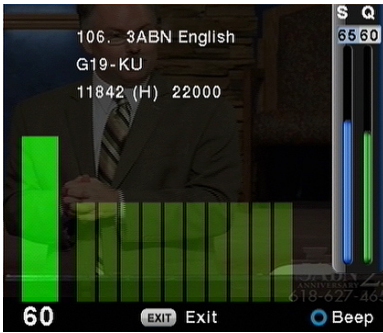

Press the CH/DOWN arrow button on the remote control to **Channel 106, 3ABN**. Verify the Signal Quality (**Q**) reading is at least 50% and displaying 3ABN programming. If the Signal Quality (**Q**) is less than 50%, make very small adjustments to fine tune the dish elevation and azimuth (side to side).

Place the receiver on **Channel 113, Cornerstone TV**. Verify the Signal Quality (**Q**) reading is at least 50% and displaying a picture. If the Signal Quality (**Q**) is less than 50%, make very small adjustments to fine tune the dish.

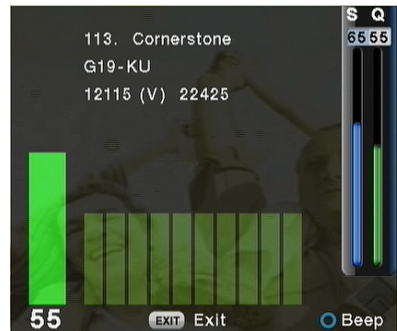

Slight clockwise or counter clockwise adjustments to the LNBF rotation or sliding the LNBF towards the reflector or away from the reflector may also provide increased Signal Quality (**Q**) readings.

Change between **Channels 901, 106 and 113** and balance for peak Signal Quality (**Q**) readings. The Glorystar system will have the best performance when the Signal Quality (**Q**) Levels are peaked and balanced on all channels and weakest channel has a Signal Quality (**Q**) reading at or above 50%.

If any channel displays a Signal Quality (**Q**) reading below 50%, additional fine tuning adjustments must be made.

The higher the Signal Quality (**Q**) reading, the better the reception. If the Signal Quality (**Q**) reading is too low, the picture will break up into little squares and the sound may become garbled, out of sync, choppy or disappear completely!

Updating the Glorystar Channel List

This Glorystar satellite receiver has been preprogrammed with a basic list of channels necessary for installation. Before attempting to update the Glorystar Channel List, verify Signal Quality (**Q**) of at least 50% on **Channel 113, Cornerstone TV**. The Automatic Channel Update feature requires a 50% Signal Quality (**Q**) Reading on Channel 113 and displaying the Cornerstone programming to reliably update the receiver.

To manually update the receiver with the current list of all available Glorystar channels use this simple **UPDATE NOW** feature.

- Press **Menu**
- Press **Left Arrow** to **Accessory Menu**
- Highlight **OTA**. Press **OK**
- Verify **OTA Update** feature is **ON**
(if not, press the **Right Arrow** to select **ON**)
- Highlight **UPDATE NOW**
- Press **OK**
- Confirm **Signal: OK** (if fail, adjust the dish)
- Press **OK** to update
- The update will take several minutes. The receiver will restart on Glorystar Channel #1. Leave the receiver tuned to Channel #1 for at least 10 - 15 seconds and the time will automatically be set.

The receiver is now updated with the most current Glorystar channels and each week automatically check for an updated channel list from the satellite.

Important Notice: Do not turn off Automatic Update!

If the Automatic Update feature is turned OFF, the channel list will not be automatically updated. New features cannot be added to the receiver and the Glorystar informational channels will not be updated with special announcements and new programming.

Favorites Channel

If the customer prefers to view only selected channel list such as only the Adventist broadcasters, Spanish, Russian or Arabic languages, press the FAV button on the remote to choose one of these preprogrammed FAVORITE LIST. Example: Select FAV - ADVENTIST to only receive the Adventist channels.

Two Room Install - (optional)

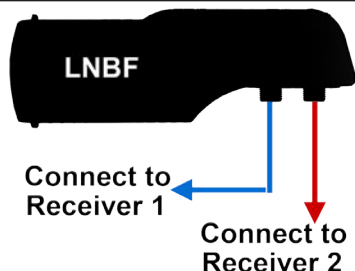

Do not use existing coax cables or switches. It is not possible use splitters to connect a single output LNBF to multiple receivers.

Splitters **DO NOT** work!

Multiple Room Install - (optional)

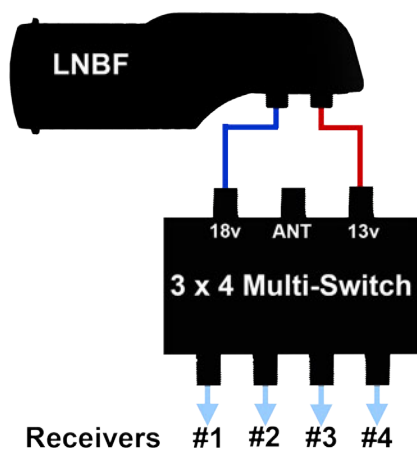

Glorystar systems support multi-room systems for any size of facility. One receiver or hundreds of receivers, Glorystar has a solution!

